

Overview

Bolted chain coupling for RW45 - tube

Product number: 37037125

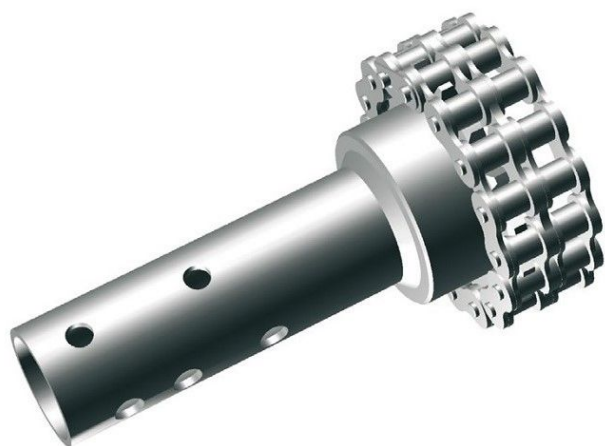

Description

The chain coupling connects an existing chain wheel at the gear motor with a drive shaft and help tos to create a more flexible drive system.

The coupling gets heat sealed on top of the drive shaft.

The double chain of this coupling enables the drive shaft to move in the line. This construction creates the higher flexibility of this drive system during dynamic external influences and during movements within the greenhouse construction.

Material: Galvanized steel

Ridder Art.-Nr.: 590002

Created at 14.03.2025.

* Our offers are directed exclusively to companies. We do not conclude contracts with consumers. All prices excl. VAT plus shipping costs and possible delivery charges, if not stated otherwise.